

# Dual-Mode Integrated Circuit for Imaging and HIFU With 2-D CMUT Arrays

Ji Hoon Jang\*, Morten Fischer Rasmussen\*, Anshuman Bhuyan\*, Hyo-Seon Yoon\*, Azadeh Moini\*, Chienliu Chang\*, Ronald D watkins†, Jung Woo Choe\*, Amin Nikoozadeh\*, Douglas Stephens‡, Ömer Oralkan§, Kim Butts Pauly†, Butrus Khuri-Yakub\*

\*Electrical Engineering, Stanford University, Stanford, USA

†Radiology, Stanford University, Stanford, USA

‡Biomedical Engineering, University of California, Davis, USA

§Electrical and Computer Engineering, North Carolina State University, Raleigh, USA

**Abstract**—Successful high intensity focused ultrasound (HIFU) operation requires a reliable guidance and monitoring method such as magnetic resonance imaging (MRI) or ultrasound imaging. However, both widely used modalities are typically separate from the HIFU system, which makes co-registration of HIFU with cross-sectional imaging difficult. In this paper, we present a dual-mode integrated circuit (IC) that can perform both ultrasound imaging and HIFU with a single 2D capacitive micromachined ultrasonic transducer (CMUT) array, combining these two systems for ease of use. The dual-mode IC consists of pulsers, transmit beamforming circuitry, and low-noise amplifiers for imaging mode and switches for HIFU mode. By turning this switching network on and off, the system can alternately operate the imaging mode and HIFU mode on demand. The dual-mode IC was designed and fabricated in the 0.18- $\mu\text{m}$  HV 4LM process provided by Maxim Inc. We fabricated a  $32 \times 32$ -element CMUT array that has a center frequency of 5 MHz using a sacrificial release process and flip-chip bonded this CMUT array to the IC. With the back-end system, real-time volumetric imaging on the wire phantom and HIFU ablation on ex-vivo tissue were performed respectively.

## I. INTRODUCTION

High intensity focused ultrasound, or HIFU, has been widely used to treat solid tumours, including those of the prostate, liver, breast, kidney, bone and pancreas, because of its precise ablation and its very few side effects [1]. For successful HIFU operation, it is important to have a reliable guidance and treatment monitoring method such as magnetic resonance imaging (MRI) or ultrasound imaging. MRI is an effective tool for planning the precise ablation trajectory for a focused ultrasound beam and tracking the temperature changes, but the tool itself is expensive and it is not compatible with some devices [2]. Ultrasound imaging generates lower quality spatial resolution than MRI but better visualization in real time with low cost [2]. Both modalities have their own advantages and disadvantages, but both of them have the same difficulty in the co-registration of HIFU with cross-sectional imaging because they are typically integrated with a separate HIFU system. This is often due to the fact that the conventional piezoelectric transducer for HIFU has a narrower bandwidth, which prevents the use of a single transducer for both imaging and HIFU. On the other hand, the wide bandwidth of capacitive micromachined ultrasonic transducers (CMUTs) enables the

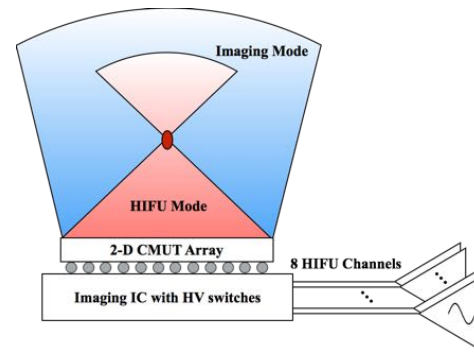

Fig. 1. Illustration of overall imaging and HIFU setup.

use of the same transducer array for both therapy and imaging. To take advantage of CMUT technology and address both imaging and HIFU operation with a single 2D CMUT array, we developed a dual-mode integrated circuit (IC) that can perform both ultrasound imaging and HIFU. The dual-mode IC consists of pulsers, transmit beamforming circuitry, and low-noise amplifiers for imaging mode, and switches for HIFU mode. By turning this switching network on and off, the system can alternately operate in imaging mode or HIFU mode on demand.

In the following sections, the overall system setup for dual-mode operation is first described. Then, a  $32 \times 32$ -element CMUT array as well as the integrated circuit for dual-mode operation are explained. Also, real-time volumetric images and ablation of ex-vivo tissue are presented.

## II. SYSTEM DESIGN FOR DUAL-MODE OPERATION

Previously, we have designed an imaging IC for real-time volumetric imaging [3]. The pulsers in this imaging IC can transmit up to 60 V for HIFU operation, but this would require high power dissipation and would quickly heat the chip. It would be impractical to use this chip in a clinical setting with patients as it might cause severe burns. Therefore, we designed a High-Voltage (HV) switch that connects the CMUT array to off-chip pulsers in HIFU mode. Most of the power consumption in HIFU mode is outsourced to the off-chip pulsers, which are not in contact with the patient

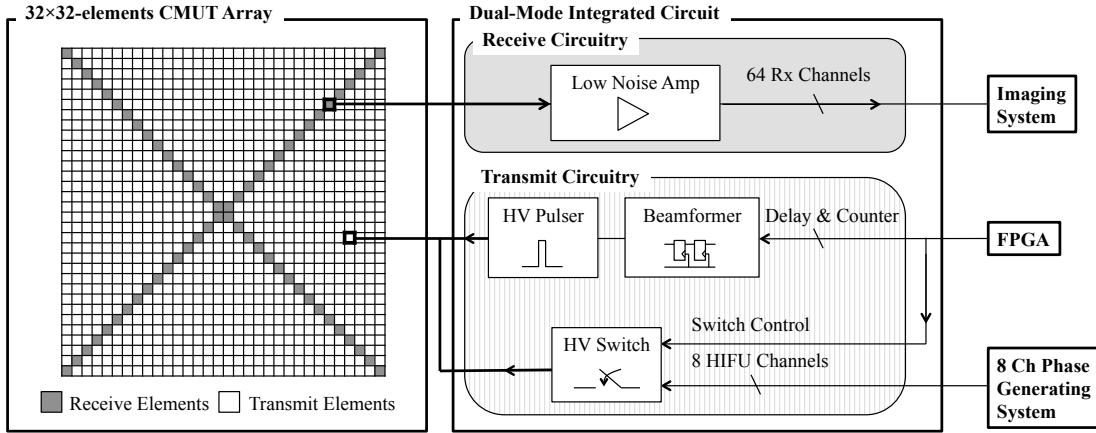

Fig. 2. System block diagram of the CMUT array, the dual-mode integrated circuit, and the back-end system.

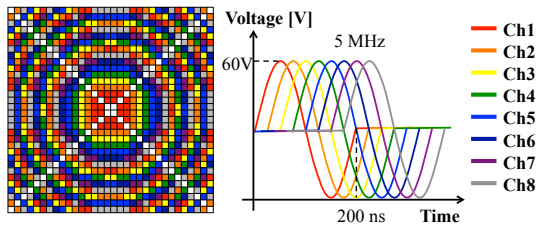

Fig. 3. The channel grouping of the CMUT elements for HIFU mode and 8 HIFU channel pulse with 45-degree phase shift.

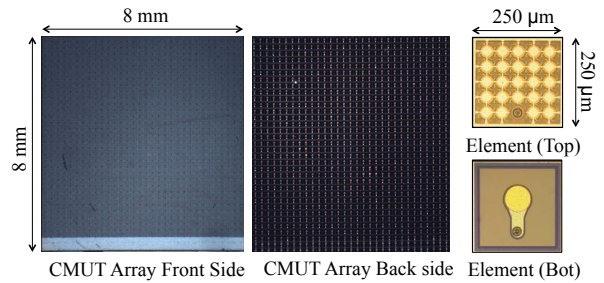

Fig. 4. Optical picture of 32×32-element CMUT array front and back side.

at the time of the medical procedure. With this proposed design, the dual-mode system operates in ultrasound imaging mode and HIFU mode by using the imaging circuits in the IC during imaging mode and off-chip pulsers to generate the high-voltage pulse during ablation therapy.

Fig. 1. illustrates the overall system setup including a 2-D CMUT array, a dual-mode IC and back-end system. In imaging mode, the on-chip pulsers are timed to steer the ultrasound beam. In HIFU mode, the multiple off-chip pulsers transmit pulses with different phases to achieve the desired focus. To reduce the complexity of the system, the focal depth is fixed to be  $f-1$  and the transmit CMUT elements are grouped into 8 HIFU channels based on the phase delay from each element to the desired focal point as shown in Fig. 3.

### III. 32×32-ELEMENT CMUT ARRAY

We fabricated a 32×32-element CMUT array with an aperture of 8 mm×8 mm. It has a center frequency of 5 MHz in immersion and an element-to-element pitch of 250 μm in both directions using the sacrificial release process as described in [4]. The CMUT DC bias is brought in to all elements through the CMUT top plate, and the AC signal is brought in to each individual element through backside pads on the CMUT as shown in Fig. 4. Each CMUT element is connected to either transmit circuitry or receive circuitry via these backside flip chip pads. In this system, only the 64

diagonal CMUT elements are used as receivers; the other 960 elements transmit the ultrasound beam for both imaging and HIFU mode as shown in Fig. 2. With this scheme, we reduce the number of the back-end cables without significant loss of image quality as shown by Wygant et al. [5].

### IV. DUAL-MODE INTEGRATED CIRCUIT DESIGN

The system block diagram of the dual-mode IC is illustrated in Fig. 2. The circuit for imaging-mode is similar to the circuit described in [6]. The pulser excites the CMUT element with a unipolar pulse up to 60 V with a slew rate of 1250 MV/sec when the 8-bit delay matches the 8-bit global counter. The delay value is loaded and the global counter frequency is set based on the phase delay from each of the transmit elements to the desired focal point. In this way, we can steer the beam for transmit beamforming. The receivers connected to the diagonal CMUT elements include transimpedance amplifiers and buffers with a 200 kΩ gain, 20 MHz bandwidth, and noise figure of 4.5 dB at 5 MHz. Each channel consumes 4.5 mW.

The High-Voltage (HV) switches for HIFU mode either pass or isolate the high voltage pulse. A simple pass-gate transistor configuration cannot be used because it cannot pass a high-voltage pulse. In typical HV processes, the HV devices have a high drain-to-source ( $V_{DS}$ ) but a low gate-to-source ( $V_{GS}$ ) breakdown voltage limit. Thus, in the pass-gate transistor configuration, the passing voltage from the drain to the source

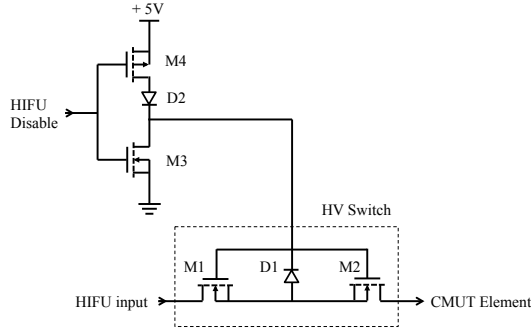

Fig. 5. Schematic of High-Voltage switch.

is limited by the  $V_{DS} - V_T$ , where  $V_{DS}$  is drain-to-source voltage and  $V_T$  is threshold voltage of the transistor. For example, if a high-voltage n-channel transistor has a  $V_{GS}$  limit of 5 V, a  $V_{DS}$  limit of 60 V, and a  $V_T$  of 1 V, the maximum voltage this transistor could pass would be 4 V. Therefore, an alternative architecture was needed to fulfill our requirements of passing a HV pulse. We proposed a HV switch architecture illustrated in Fig. 5.

In this configuration, in order to enable the switch, the PMOS device (M4) charges the  $V_{GS}$  of the HV MOS devices (M1 and M2) to a logic high (5 V), turning on the two devices. Once the two devices M1 and M2 are on, any voltage that is seen at the drain of M1 gets passed on to the output. At this time, there is no current flowing through diode D1 due to the blocking diode D2. The  $V_{GS}$  voltages of the two devices are bootstrapped close to 5 V. Also, note that MOS transistor M3 is off when the switch is enabled. To disable the switch, the HIFU Disable signal turns on the MOS transistor M3 which starts to discharge the  $V_{GS}$  of M1 and M2. At this time, the diode D1 acts like a short bringing the drain and the source of the two transistors to the same potentials.

We were provided with high voltage transistors in Maxim's process where the  $V_{GS}$  and the  $V_{DS}$  tolerances are 5 V and 65 V, respectively. Fig. 6 shows simulation results of the switch circuitry with correct functionality, namely the passing of a sinusoidal pulse (at 60 V) when the switch is enabled and the rejection of it when it is disabled.

## V. ASSEMBLY INTEGRATION

The dual-mode IC was designed and fabricated in the 0.18- $\mu\text{m}$  HV 4LM process provided by Maxim, Inc. Fig. 7 shows a die photo of the fabricated IC. It has flip-chip pads and DC bias pads for the CMUT array in the center of the IC, and I/O and power pads along the perimeter of the IC. The flip-chip pads have a Ni-Au under-bump metallization (UBM) and a solder jetting process was used to deposit solder balls. To identify and disable any shorted CMUT elements, as well as to characterize the array, the input impedance of each element of the CMUT array was measured using motorized positioner. Using custom software, the data from each element was automatically collected and categorized as

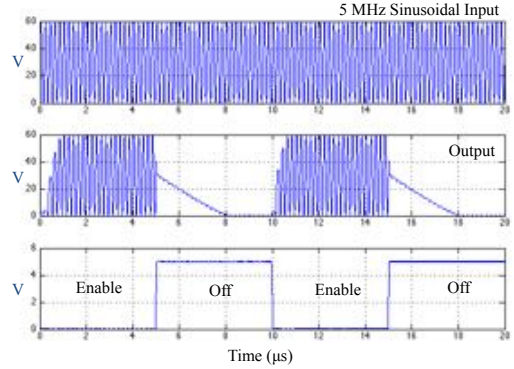

Fig. 6. Simulation results of High-Voltage switch.

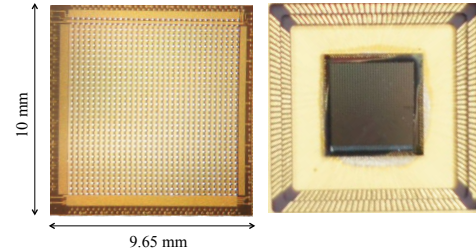

Fig. 7. Photo of the dual-mode IC and the CMUT array flip-chip bonded to IC.

'Short' or 'Normal'. Next, we manually removed the solder balls for 'Short' elements to prevent electrical contact during use. Then, we flip-chip bonded the CMUT array to the IC using an in-house flip-chip bonding machine. After successful integration, the CMUT-IC assembly was wire-bonded to a pin grid array as shown in Fig. 7.

## VI. MEASUREMENTS

Further measurements, characterization, and imaging were performed in immersion. a custom-designed printed circuit board (PCB) is used to interface the CMUT-IC assembly to the off-chip pulsers, an image reconstruction system, and a field-programmable gate array (FPGA) as shown in Fig. 8. During operation, the FPGA first sends the beam pattern to

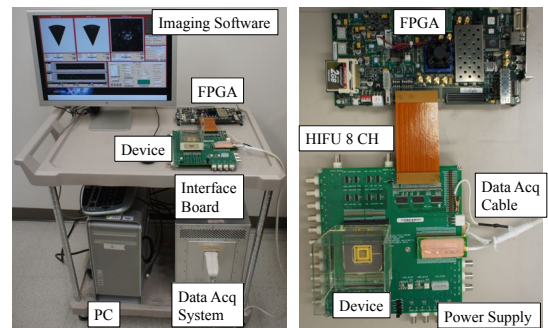

Fig. 8. Illustration of the back-end system including interface board, FPGA, data acquisition system, and PC.



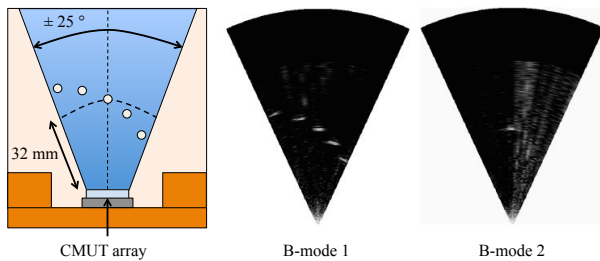

Fig. 9. Diagram of the imaging setup with a wire phantom for imaging and two-dimensional images shown log-compressed with a dynamic range of 20 dB.

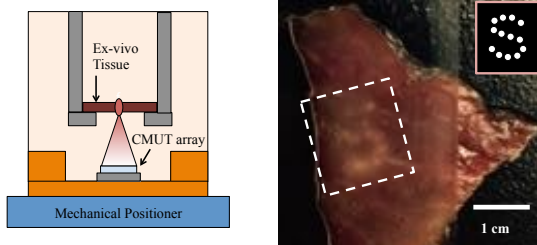

Fig. 10. Diagram of the HIFU setup and a picture of ablated ex-vivo tissue.

the transmit beamformer in the IC and controls the modes between imaging and HIFU. The imaging system processes the data received by the 64 receive channels to reconstruct real-time ultrasound images. The off-chip pulsers consist of direct digital synthesizers and power amplifiers to drive 8 HIFU channels.

Using the described set up, the dual-mode IC was first tested in imaging mode to image a nylon wire phantom. Each wire had a 300  $\mu\text{m}$  diameter. The CMUT was biased at 35 V and the on-chip pulser transmit a unipolar pulse of 20V. We transmitted  $25 \times 25$  beams in  $\pm 25$  degree and used conventional phased array imaging to acquire the images. The images were reconstructed by custom receive beamforming software [7]. The data is displayed in two orthogonal B-mode planes in Fig. 9.

For HIFU mode, we first verified the function of the HV switch. It successfully passed and rejected up to 60 V sinusoidal signal. Also, to confirm HIFU capability of the CMUT array, the CMUT array itself without the dual-mode IC was flip-chip bonded to the fan-out IC, which only provides the grouping of the elements and the connection to the off-chip pulsers [8]. We measured the pressure 8.5 MPa at focal depth of 9 mm using a hydrophone with a 60  $V_{pp}$  AC pulse and 40 V DC CMUT bias [8]. After confirming that the pressure is enough to ablate the tissue, we performed HIFU ablation on ex-vivo tissue with DC 40 V and AC 60  $V_{pp}$  as shown in Fig. 10 [8]. Currently, we are working on testing HIFU mode with dual-mode IC and developing a switching program for dual-mode operation.

## VII. CONCLUSION

We designed and tested a dual-mode integrated circuit for ultrasound imaging and HIFU with a single 2-D  $32 \times 32$  CMUT array. The dual-mode IC includes the transmit beamforming circuitry, receivers for imaging mode and HV switches for HIFU mode. The transmit CMUT elements are connected to either the on-chip pulsers by turning off the switch or one of the 8 HIFU channels connected to off-chip pulsers. We demonstrated imaging mode of the dual-mode IC using the conventional phased array imaging with the wire phantom. The functionality of the HV switch was tested and the capability of the CMUT array for HIFU operation was confirmed by first measuring the pressure at the focal depth and then by performing ablation on ex-vivo tissue. Currently, we are developing a switching program for dual-mode operation of the system on ex-vivo tissue in real time. Furthermore, we have integrated the devices with a custom flexible PCB which will be used for in-vivo testing.

## ACKNOWLEDGMENT

This work was supported by the National Institutes of Health under grant R01HL117740. We would like to thank Maxim Corporation for their valuable support in the fabrication of the IC. CMUT fabrication was done at the Stanford Nanofabrication Facility (Stanford, CA). We would like to thank Pauline Prather for her support during wire-bonding and assembly. We also thank Verasonics for their programming support.

## REFERENCES

- [1] E. K. James, "High-intensity focused ultrasound in the treatment of solid tumours." *Nature Review Cancer*, vol. 5, pp. 321–327, April 2005.
- [2] S. Li and W. Pei-Hong, "Magnetic resonance image-guided versus ultrasound-guided high-intensity focused ultrasound in the treatment of breast cancer." *Chinese Journal of Cancer*, vol. 32.8, pp. 441–452, 2013.
- [3] I. Wygant, N. Jamal, H. Lee, A. Nikoozadeh, O. Oralkan, M. Karaman, and B. Khuri-Yakub, "An integrated circuit with transmit beamforming flip-chip bonded to a 2-d cmut array for 3-d ultrasound imaging." *Ultrasonics, Ferroelectrics and Frequency Control, IEEE Transactions on*, vol. 56, no. 10, pp. 2145–2156, 2009.
- [4] A. S. Erguri, Y. Huang, X. Zhuang, O. Oralkan, G. G. Yarahoglu, and B. Khuri-Yakub, "Capacitive micromachined ultrasonic transducers: fabrication technology," *Ultrasonics, Ferroelectrics and Frequency Control, IEEE Transactions on*, vol. 52, no. 12, pp. 2242–2258, 2005.
- [5] I. Wygant, M. Karaman, O. Oralkan, and B. Khuri-Yakub, "Beamforming and hardware design for a multichannel front-end integrated circuit for real-time 3-d catheter-based ultrasonic imaging." in *Proc. SPIE - med. imag.*, vol. 6147, 2006.
- [6] A. Bhuyan, J. W. Choe, B. Lee, I. Wygant, A. Nikoozadeh, O. Oralkan, and B. Khuri-Yakub, "Integrated circuits for volumetric ultrasound imaging with 2-d cmut arrays." *Biomedical Circuits and Systems, IEEE Transactions on*, vol. 7, no. 10, pp. 796–804, December 2013.
- [7] J. W. Choe, O. Oralkan, A. Nikoozadeh, A. Bhuyan, B. Lee, M. Gencel, and B. Khuri-Yakub, "Real-time volumetric imaging system for cmut arrays," in *Proc. IEEE Ultrason. Symp.*, 2011, pp. 1064–1067.
- [8] H.-S. Yoon, K. Firouzi, A. Bhuyan, J. W. C. J. H. Jang, A. Nikoozadeh, C. Chang, R. D. Watkins, D. N. Stephens, K. B. Pauly, and B. Khuri-Yakub, "A dual-mode integrated 2-d cmut array for real-time volumetric imaging and hifu," in *Presented at the 15th International Symposium on Therapeutic Ultrasound, Utrecht, Netherlands*, April 15-18 2015.